

Theme 4
 The arm actions in measures 105 - 114 serve to accent the music as the dancer desires.

There is a slight out and over push before you lower your wands

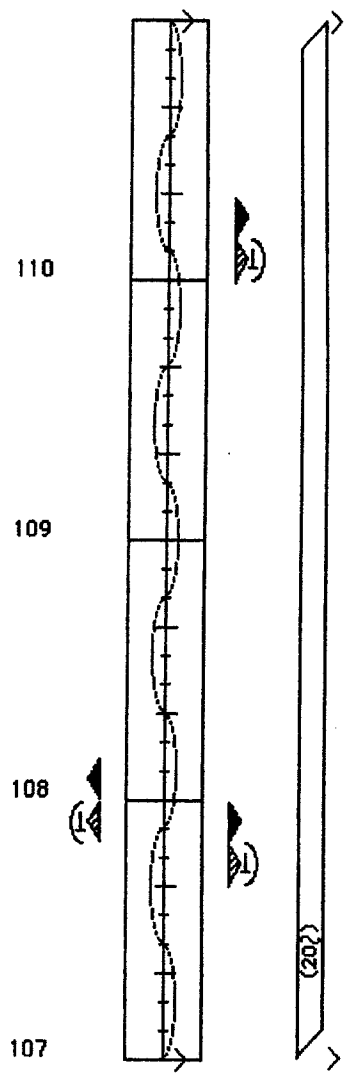

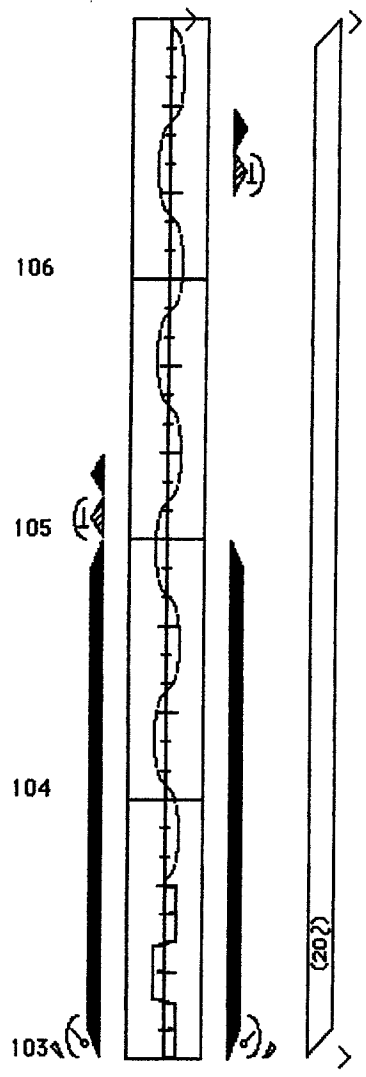

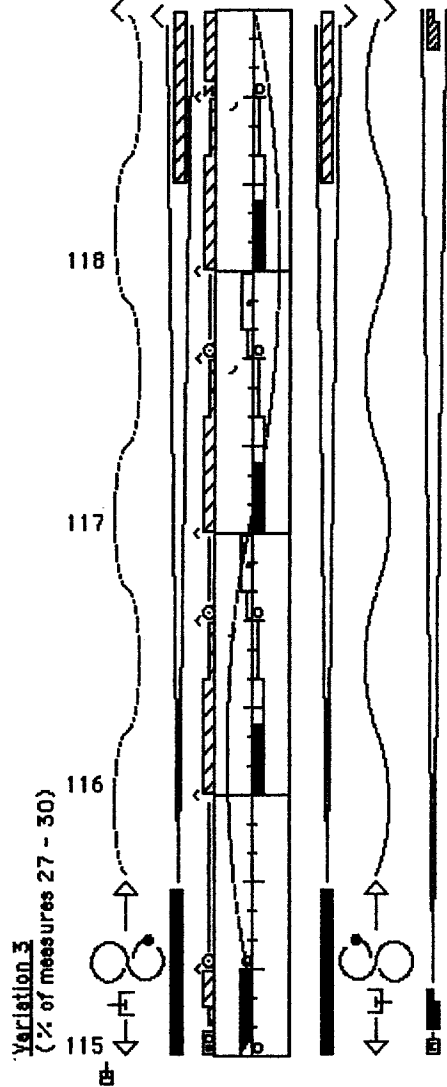
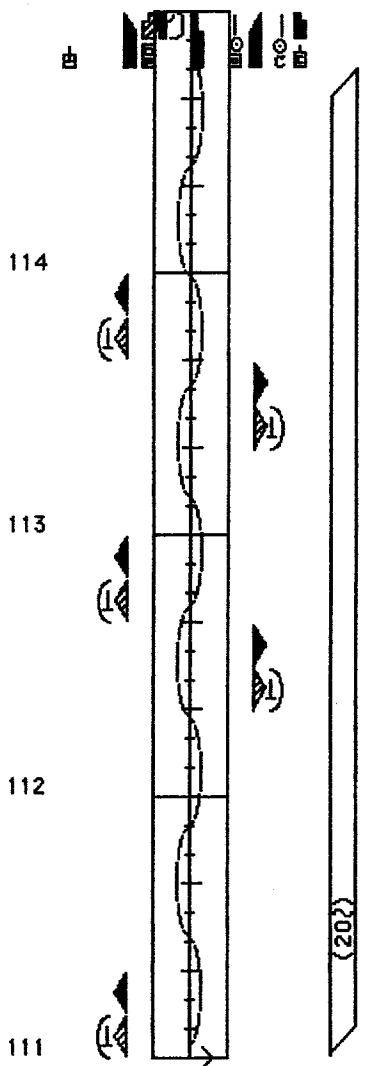
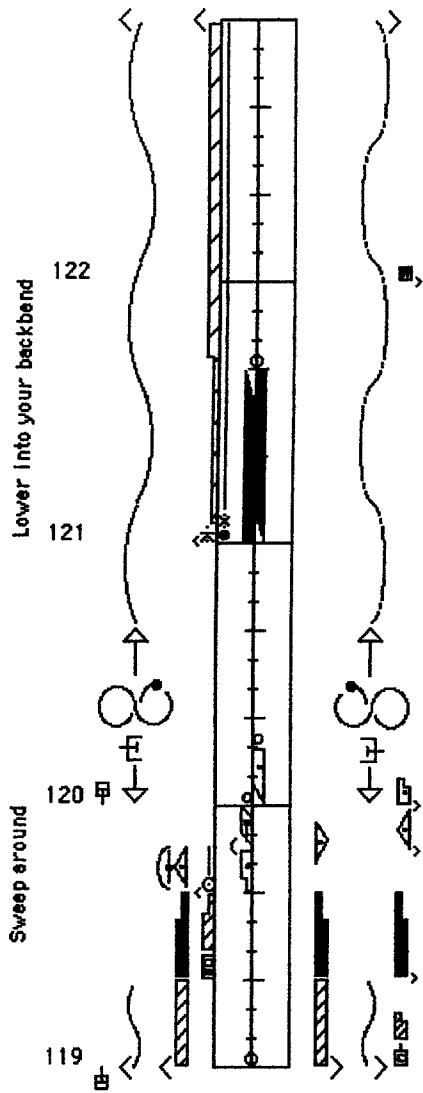

Hold in your backbend as the lights turn deep red

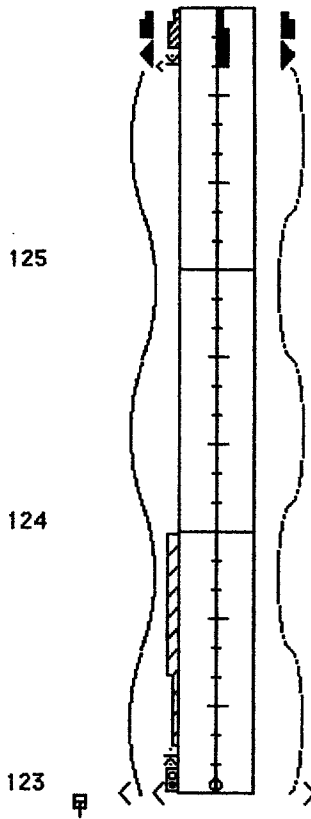

Theme 5 & Variation 4

First Corner
(similar to measures 59 - 62)

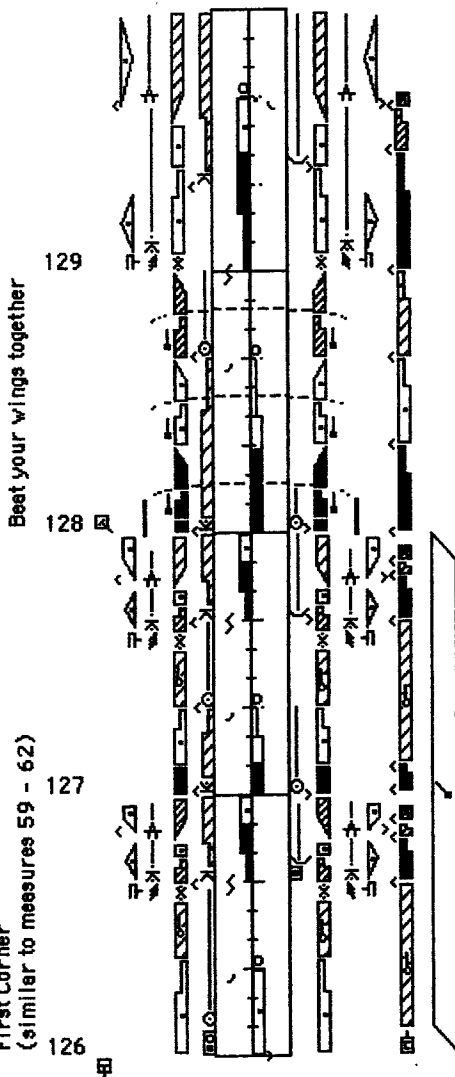

Second Corner

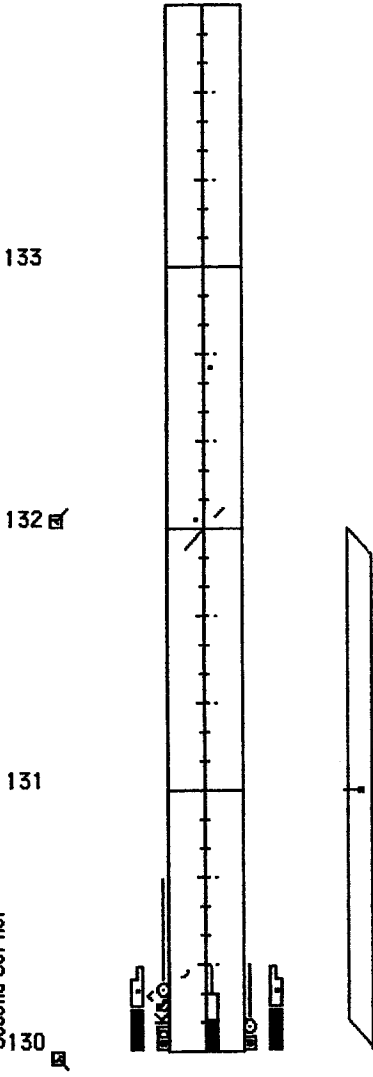

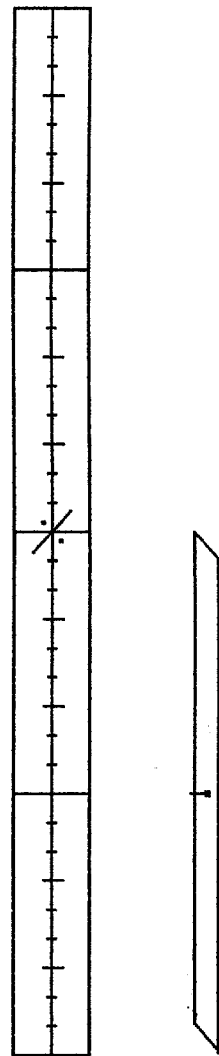
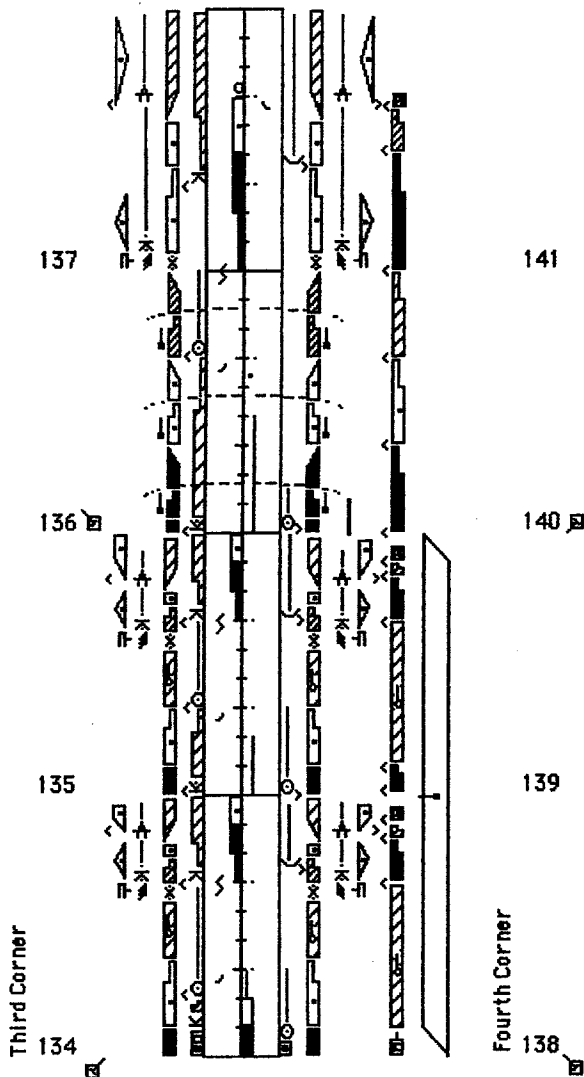

Similar to the sweeps in measures 50 - 52

Development 2

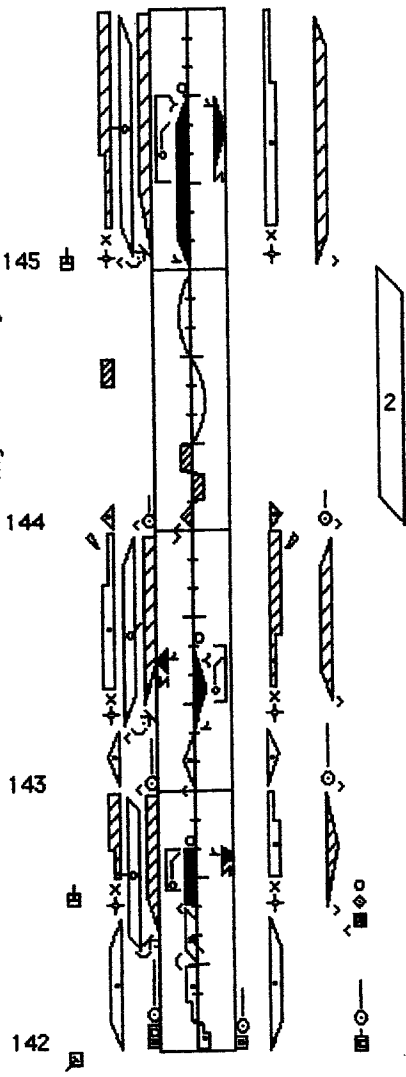

Asymmetrical Lily

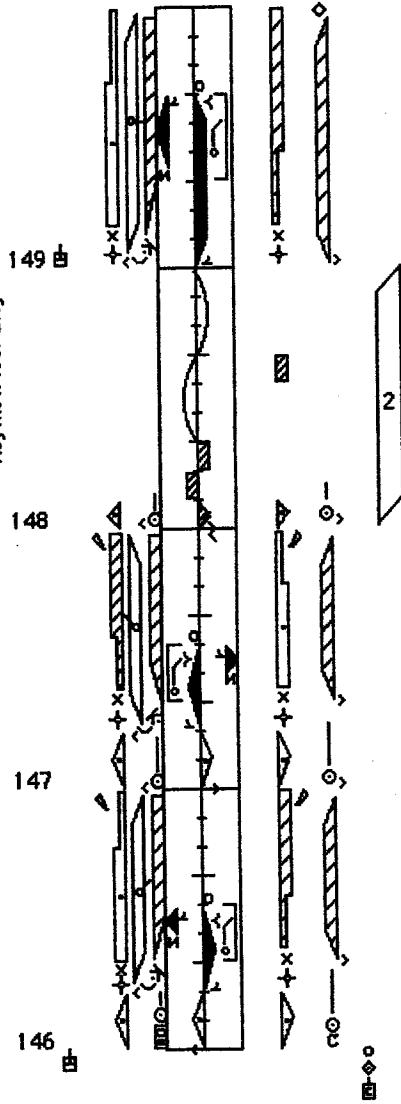

Big circular sweep in the lateral plane (1/4 of measure 150)

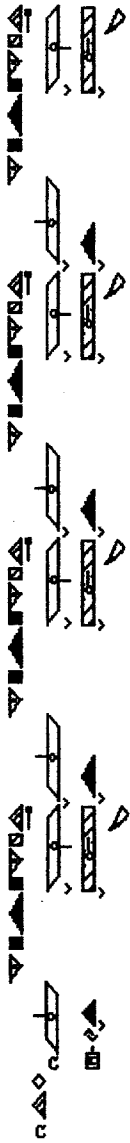
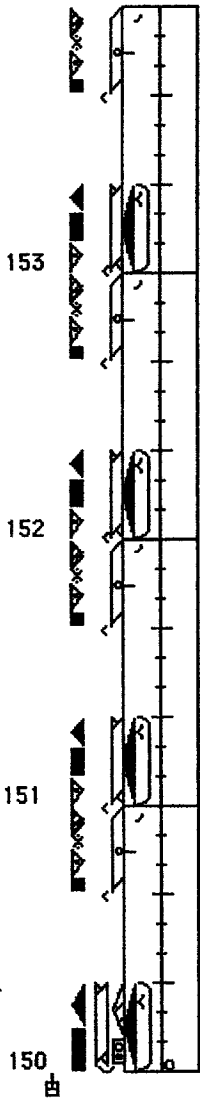

Crescendo
The final display of your power

Sway gently as if blown by a soft wind

Swing up into a Full Lily

